

## Description

### General

The transceiver from SANOC is small form factor pluggable module with standard duplex connector for fiber communications. This module is designed for single-mode-fiber (SMF) and operates at a nominal wavelength of 1550 nm with cost effective and high performance. It is with the SFP 20-pin connector to allow hot plug capability.



### Transmitter Section

The transmitter consists of a high-performance 1550 nm MQW DFB structure laser in the optical subassembly (OSA), which is housed within a metal package. In addition, this component is also class 1 laser compliant with according to International Safety Standard IEC-825 Compliant. Complies with EN60825-1 and FDA 21 CFR 1040.10 and 1040.11

SFP Duplex SMF Transceiver	
LC Type	SI1562-80ATOS(WT)
LC Type with DDM	SJ1562-80ATOS(WT)

### Receiver Section

The receiver contain of an InGaAs PIN photodiode coupled to a high sensitivity transimpedance amplifier (TIA) in an OSA. This OSA combination is mated to a post amplifier IC that provides the post amplification and SD (Signal Detection) or LOS (Loss of Signal) indication circuit, which provides logic high state output when an unusable input optical signal level is detected.

## Features

- Single + 3.3V power supply
- Differential Inputs and Outputs
- Small Form Factor Pluggable MSA Compliant.
- Compliant with SFF-8472 MSA Digital Diagnostic Monitor (DDM), Internal Calibration. (SJ Series)
- Class 1 Laser International Safety Standard IEC 825 Compliant. Complies with EN60825-1 and FDA 21 CFR 1040.10 and 1040.11
- Commercial Operation Temp.: 0 °C to +70 °C
- Industrial Operation Temp.: -40 °C to +85 °C
- RoHS Compliant

## Applications

- ATM switch, SONET OC-12 / SDH STM-4
- Bridges/Routers/intelligent hub and concentrators
- Fast Ethernet

## Performance Specifications

Absolute Maximum Ratings						
Parameter	Symbol	Min	Typ	Max	Unit	
Supply Voltage	V <sub>CC</sub>	0	-	4	V	
Storage Temperature	T <sub>S</sub>	-40	-	85	°C	
Operating Temperature	Commercial	T <sub>OP-com</sub>	0	-	70	°C
	Industrial	T <sub>OP-ind</sub>	-40	-	85	°C
General Specifications						
Parameter	Symbol	Min	Typ	Max	Units	
Data Rate	B	200	622	800	Mbps	
Supported Link Length on 9/125µm SMF	L	80	-	-	Km	
Supply Current	I <sub>Tx+Rx</sub>	-	-	300	mA	
Power Dissipation	P <sub>Dis</sub>	-	-	1000	mW	

### Optical and Electrical Characteristics

Transmitter Electrical Characteristics					
Parameter	Symbol	Min	Typ	Max	Unit
Supply Voltage	$V_{CC}$	3.15	3.3	3.45	V
Data Differential Input Voltage	$V_{in, pp}$	400	-	2000	mV
Disable Input Voltage	$V_{IL} - V_{CC}$	-1.81	-	-1.48	V
Enable Input Voltage	$V_{IH} - V_{CC}$	-1.16	-	-0.88	V
TX Fault Voltage-High (Fault)	$V_{TF}$	2.0	-	$V_{CC}$	V
TX Fault Voltage-Low (Normal)	$V_{TN}$	0	-	0.8	V
Transmitter Optical Characteristics					
Parameter	Symbol	Min	Typ	Max	Unit
Output Optical Power on 9 $\mu$ m SMF	$P_O$	-3	-	+2	dBm
Center Wavelength	$\lambda_C$	1510	1550	1570	nm
Side Mode Suppression Ratio	SMSR	30	-	-	dB
Spectral Width (-20dB)	$\Delta\lambda$	-	-	1	nm
Optical Rise Time (20%-80%)	$t_r$	-	-	0.5	ns
Optical Fall Time (20%-80%)	$t_f$	-	-	0.5	ns
Extinction Ratio	ER	8.2	-	-	dB
P <sub>Out</sub> @TX Disable Asserted	$P_{OFF}$	-	-	-45	dBm
Output eye	Compliant with Telcordia GR-253-CORE Issue 3 and ITU-T recommendation G.957				

Receiver Electrical Characteristics					
Parameter	Symbol	Min	Typ	Max	Unit
Supply Voltage	$V_{CC}$	3.15	3.3	3.45	V
Data Differential Output Voltage	$V_{out, pp}$	500	-	1200	mV
Receiver LOS/SD Output Voltage-High	$V_{RH}$	2.0	-	$V_{CC}$	V
Receiver LOS/SD Output Voltage-Low	$V_{RL}$	0	-	0.8	V
Data Output Rise Time (20%-80%)	$t_r$	-	-	0.5	ns
Data Output Fall Time (20%-80%)	$t_f$	-	-	0.5	ns
Receiver Optical Characteristics					
Parameter	Symbol	Min	Typ	Max	Unit
Maximum Receiver Power	$P_{in}$	-3	-	-	dBm
Receiver Sensitivity	$P_S$	-	-	-28	dBm
Operating Wavelength	$\lambda_C$	1100	-	1600	nm
Optical Return Loss	$P_R$	-	-	12	dB
Signal Detect-Asserted	$P_A$	-	-	-28	dBm avg.
Signal Detect-Deasserted	$P_D$	-40	-	-	dBm avg.
Signal Detect-Hysteresis	$P_A - P_D$	0.5	-	-	dB

**Eye pattern mask**

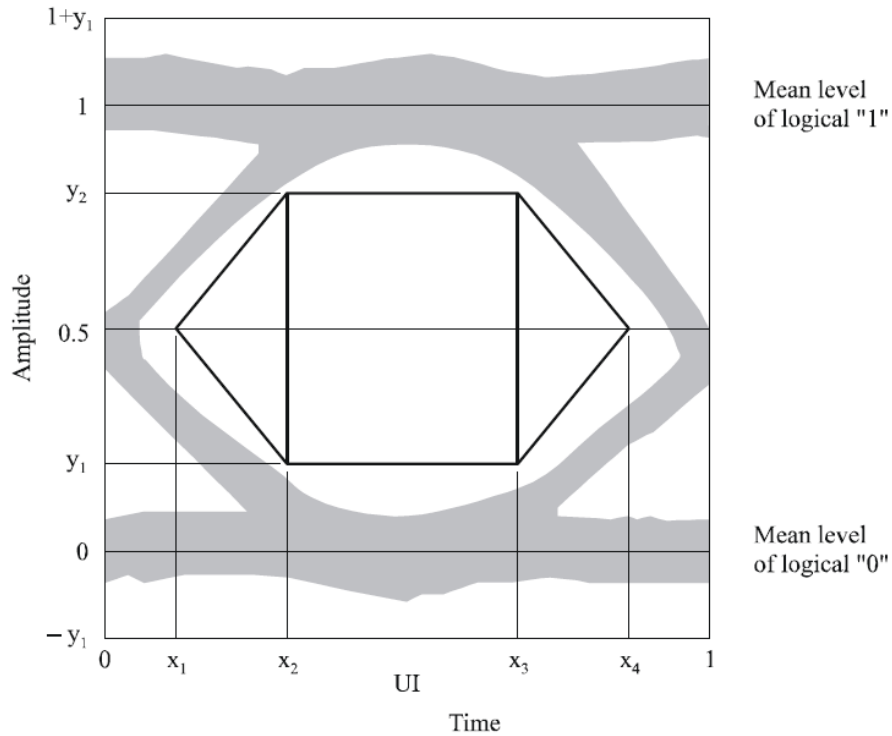

**Mask of the eye diagram for the optical transmit signal**

	STM-1	STM-4	STM-16
$x_3-x_2$	-	-	0.2
$x_1/x_4$	0.15/0.85	0.25/0.75	-
$x_2/x_3$	0.35/0.65	0.40/0.60	-
$y_1/y_2$	0.20/0.80	0.20/0.80	0.25/0.75

**Ordering Information**

**SI1562-80ATOS(WT)** → (WT) : Industrial Temp. / None : Commercial Temp.

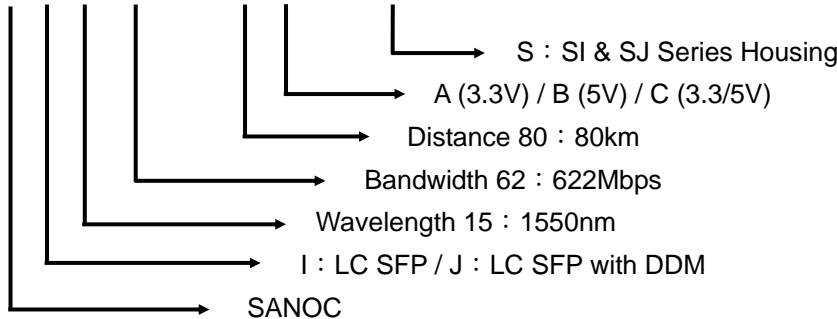

**Recommended Circuit Schematic**

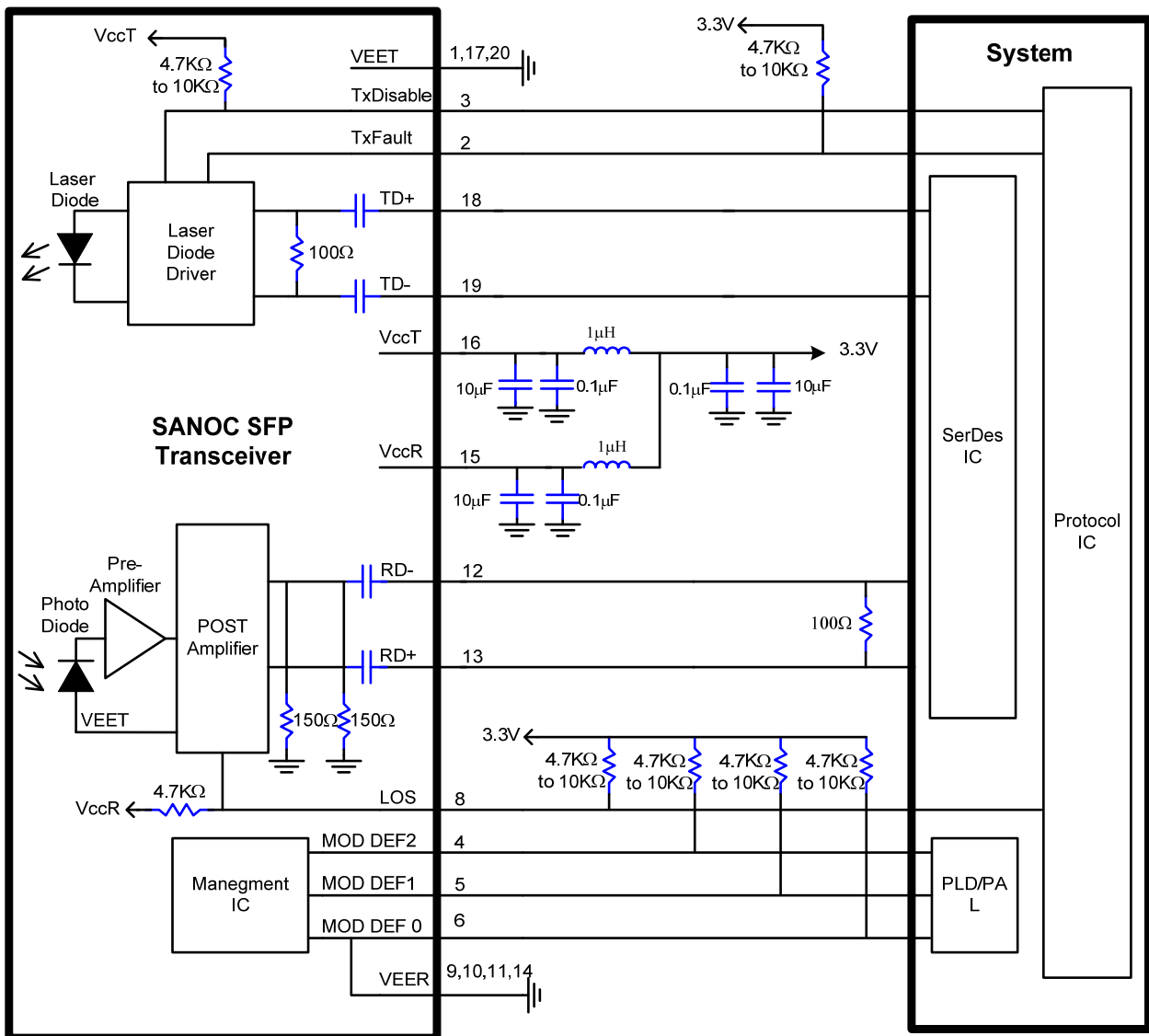

**SFP Transceiver Electrical Pad Layout**

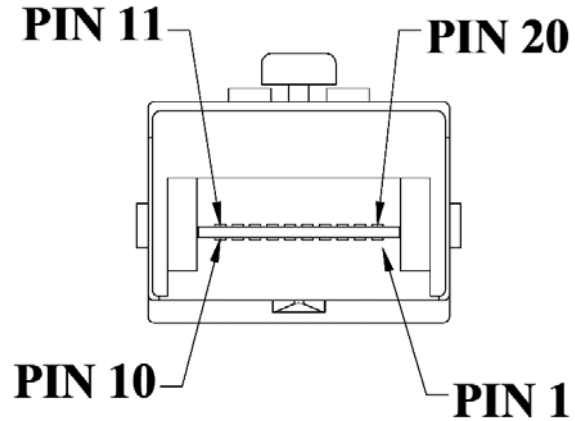
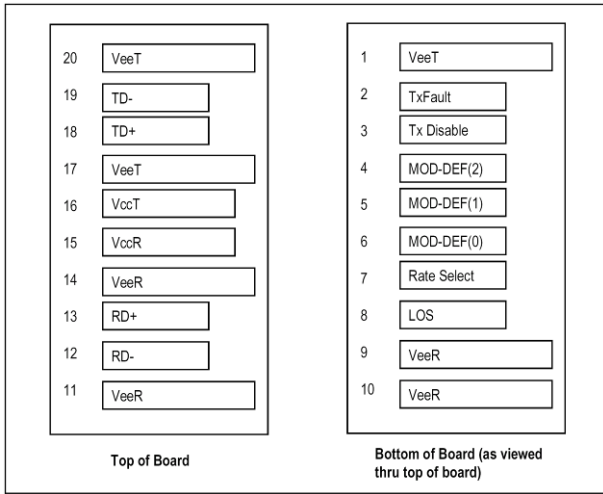

**Pinout Table**

Pin	Symbol	Name/Description	Ref.
1	V <sub>EET</sub>		
2	T <sub>FAULT</sub>	Transmitter Fault.	3
3	T <sub>DIS</sub>	Transmitter Disable. Laser output disabled on high or open.	1
4	MOD_DEF (2)	Module Definition 2. Data line (SDA) for Serial ID.	2
5	MOD_DEF (1)	Module Definition 1. Clock line (SCL) for Serial ID.	2
6	MOD_DEF (0)	Module Definition 0. Grounded within the module.	2
7	Rate Select	Open Circuit	
8	LOS	Loss of Signal indication. Logic 0 indicates normal operation.	3
9	V <sub>EER</sub>	Receiver Ground	
10	V <sub>EER</sub>	Receiver Ground	
11	V <sub>EER</sub>	Receiver Ground	
12	RD-	Receiver Inverted DATA out. AC Coupled	
13	RD+	Receiver Non-inverted DATA out. AC Coupled	
14	V <sub>EER</sub>	Receiver Ground	
15	V <sub>CCR</sub>	Receiver Power Supply	
16	V <sub>CCT</sub>	Transmitter Power Supply	
17	V <sub>EET</sub>	Transmitter Ground	
18	TD+	Transmitter Non-Inverted DATA in. 100 ohm termination between TD+ and TD-, AC Coupled thereafter.	
19	TD-	Transmitter Inverted DATA in. See TD+	
20	V <sub>EET</sub>	Transmitter Ground	

**Notes:**

1. Laser output disabled on TDIS >2.0V or open, enabled on TDIS <0.8V.
2. Should be pulled up with 4.7k – 10kohms on host board to a voltage between 2.0V and 5.5V. MOD\_DEF (0) pulls line low to indicate module is plugged in.
3. TX-Fault and LOS are open collector output. Should be pulled up with 4.7k – 10k ohms on host board to a voltage between 2.0V and 5.5V.

**Memory map**

The memory map in the following describes an extension to the memory map defined in SFP MSA. The enhanced interface uses the two wire serial bus address 1010001X(A2h) to provide diagnostic information about the module's present operating conditions.

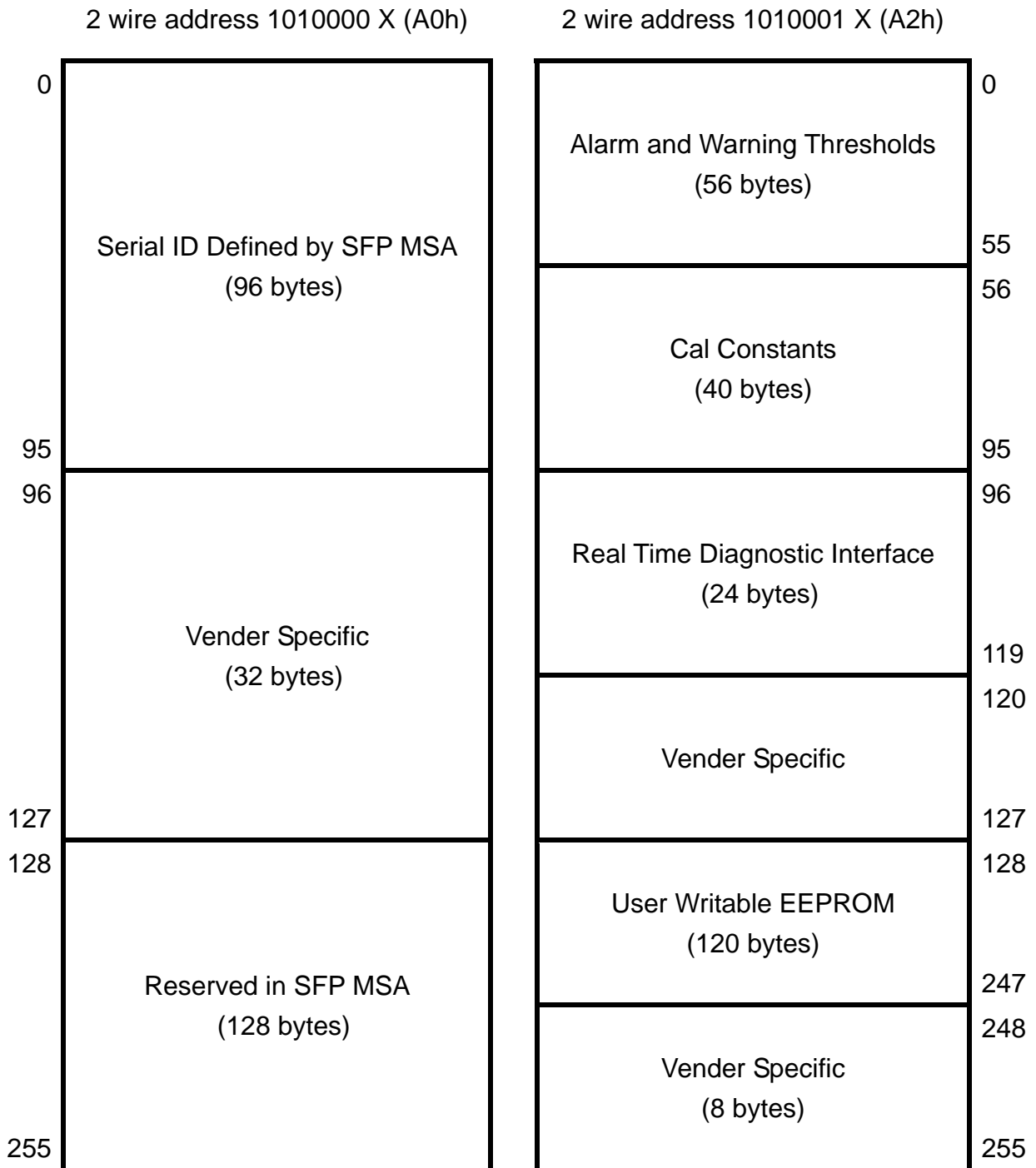

**2 Wire Address (A0h, interface ID: Data Fields)**

Address	Bytes	Name	Description
<b>BASE ID FIELDS</b>			
0	1	Identifier	Type of transceiver
1	1	Ext. Identifier	Extended identifier of type of transceiver
2	1	Connector	Code for connector type
3-10	8	Transceiver	Code for electronic or optical compatibility
11	1	Encoding	Code for high speed serial encoding algorithm
12	1	BR, Nominal	Nominal signal rate, units of 100MBd.
13	1	Rate Identifier	Type of rate select functionality
14	1	Length(SMF,km)	Link length supported for single mode fiber, units of km
15	1	Length (SMF)	Link length supported for single mode fiber, units of 100 m
16	1	Length (50µm)	Link length supported for 50 µm OM2 fiber, units of 10 m
17	1	Length (62.5µm)	Link length supported for 62.5 µm OM1 fiber, units of 10 m
18	1	Length (cable)	Link length supported for copper or direct attach cable, units of m
19	1	Length (OM3)	Link length supported for 50 µm OM3 fiber, units of 10 m
20-35	16	Vendor name	SFP vendor name (ASCII)
36	1	Transceiver	Code for electronic or optical compatibility
37-39	3	Vendor OUI	SFP vendor IEEE company ID
40-55	16	Vendor PN	Part number provided by SFP vendor (ASCII)
56-59	4	Vendor rev	Revision level for part number provided by vendor (ASCII)
60-61	2	Wavelength	Laser wavelength (Passive/Active Cable Specification Compliance)
62	1	Unallocated	
63	1	CC_BASE	Check code for Base ID Fields (addresses 0 to 62)
<b>EXTENDED ID FIELDS</b>			
64-65	2	Options	Indicates which optional transceiver signals are implemented
66	1	BR, max	Upper bit rate margin, units of %
67	1	BR, min	Lower bit rate margin, units of %
68-83	16	Vendor SN	Serial number provided by vendor (ASCII)
84-91	8	Date code	Vendor's manufacturing date code
92	1	Diagnostic Monitoring Type	Indicates which type of diagnostic monitoring is implemented (if any) in the transceiver
93	1	Enhanced Options	Indicates which optional enhanced features are implemented (if any) in the transceiver
94	1	SFF-8472 Compliance	Indicates which revision of SFF-8472 the transceiver complies with.
95	1	CC_EXT	Check code for the Extended ID Fields (addresses 64 to 94)
<b>VENDOR SPECIFIC ID FIELDS</b>			
96-127	32	Vendor Specific	Vendor Specific EEPROM
128-255	128	Reserved	Reserved for SFF-8079

**2 Wire Address (A2h, Digital Diagnostic Monitoring Interface)**

**Alarm and Warning Thresholds**

Address	Bytes	Name
00-01	2	Temp High Alarm Thresholds
02-03	2	Temp Low Alarm Thresholds
04-05	2	Temp High Warning Thresholds
06-07	2	Temp Low Warning Thresholds
08-09	2	Voltage High Alarm Thresholds
10-11	2	Voltage Low Alarm Thresholds
12-13	2	Voltage High Warning Thresholds
14-15	2	Voltage Low Warning Thresholds
16-17	2	Bias High Alarm Thresholds
18-19	2	Bias Low Alarm Thresholds
20-21	2	Bias High Warning Thresholds
22-23	2	Bias Low Warning Thresholds
24-25	2	TX Power High Alarm Thresholds
26-27	2	TX Power Low Alarm Thresholds
28-29	2	TX Power High Warning Thresholds
30-31	2	TX Power Low Warning Thresholds
32-33	2	RX Power High Alarm Thresholds
34-35	2	RX Power Low Alarm Thresholds
36-37	2	RX Power High Warning Thresholds
38-39	2	RX Power Low Warning Thresholds
40-55	16	Reserved

**Calibration constants (2 Wire Address A2h)**

Address	Bytes	Name	Description
56-59	4	Rx_PWR(4)	Rx_PWR(4) is set to zero for "internally calibrated" devices.
60-63	4	Rx_PWR(3)	Rx_PWR(3) is set to zero for "internally calibrated" devices.
64-67	4	Rx_PWR(2)	Rx_PWR(2) is set to zero for "internally calibrated" devices.
68-71	4	Rx_PWR(1)	Rx_PWR(1) is set to 1 for "internally calibrated" devices.
72-75	4	Rx_PWR(0)	Rx_PWR(0) is set to zero for "internally calibrated" devices.
76-77	2	Tx_I(Slope)	Tx_I(Slope) is set to 1 for "internally calibrated" devices.
78-79	2	Tx_I(Offset)	Tx_I(Offset) is set to zero for "internally calibrated" devices.
80-81	2	Tx_PWR(Slope)	Tx_PWR(Slope) is set to 1 for "internally calibrated" devices.
82-83	2	Tx_PWR(Offset)	Tx_PWR(Offset) is set to zero for "internally calibrated" devices.
84-85	2	T (Slope)	T(Slope) is set to 1 for "internally calibrated" devices.
86-87	2	T (Offset)	T(Offset) is set to zero for "internally calibrated" devices.
88-89	2	V (Slope)	V(Slope) is set to 1 for "internally calibrated" devices.
90-91	2	V (Offset)	V(Offset) is set to zero for "internally calibrated" devices.
92-94	3	Reserved	Reserved
95	1	Checksum	Byte 95 contains the low order 8 bits of the sum of bytes 0 – 94.



**Digital Monitoring Values (2 Wire Address A2h)**

The digital value conversions are updated every 13ms (nominal) or 20ms (max) in rotation. After getting digital value, each measurement could be obtained by multiplying digital value by corresponding LSB value:

**Temperature (Signed twos complement value)**

A2h Byte 96 (Temperature MSB)								A2h Byte 97 (Temperature LSB)							
S	2 <sup>6</sup>	2 <sup>5</sup>	2 <sup>4</sup>	2 <sup>3</sup>	2 <sup>2</sup>	2 <sup>1</sup>	2 <sup>0</sup>	2 <sup>-1</sup>	2 <sup>-2</sup>	2 <sup>-3</sup>	2 <sup>-4</sup>	2 <sup>-5</sup>	2 <sup>-6</sup>	2 <sup>-7</sup>	2 <sup>-8</sup>

$$\text{Temperature} = \text{Temp (digital monitoring value)} \times \text{LSB}_{\text{Temp}} = \text{Temp (digital monitoring value)} \times \frac{1}{256}$$

**Vcc, TX Bias, TX Power, RX Power (Unsigned values)**

A2h Byte 98 (V <sub>cc</sub> MSB)								A2h Byte 99 (V <sub>cc</sub> LSB)							
A2h Byte 100 (TX Bias MSB)								A2h Byte 101 (TX Bias LSB)							
A2h Byte 102 (TX Power MSB)								A2h Byte 103 (TX Power LSB)							
A2h Byte 104 (RX Power MSB)								A2h Byte 105 (RX Power LSB)							
2 <sup>15</sup>	2 <sup>14</sup>	2 <sup>13</sup>	2 <sup>12</sup>	2 <sup>11</sup>	2 <sup>10</sup>	2 <sup>9</sup>	2 <sup>8</sup>	2 <sup>7</sup>	2 <sup>6</sup>	2 <sup>5</sup>	2 <sup>4</sup>	2 <sup>3</sup>	2 <sup>2</sup>	2 <sup>1</sup>	2 <sup>0</sup>

$$V_{cc} = V_{cc}(\text{digital monitoring value}) \times \text{LSB}_{V_{cc}} = V_{cc}(\text{digital monitoring value}) \times 100\mu\text{V}$$

$$\text{TX Bias Current} = \text{TX Bias Current (Digital Value)} \times \text{LSB}_{\text{TX,Bias}} = \text{TX Bias Current (Digital Value)} \times 2\mu\text{A}$$

$$\text{TX Power} = \text{TX Power (Digital Value)} \times \text{LSB}_{\text{TXPower}} = \text{TX Power (Digital Value)} \times 0.1\mu\text{W}$$

$$\text{RX Power} = \text{RX Power (Digital Value)} \times \text{LSB}_{\text{RXPower}} = \text{RX Power (Digital Value)} \times 0.1\mu\text{W}$$

**Digital Diagnostic Monitor Accuracy**

Parameter	Typical Value	Note
Transceiver Temperature	± 3°C	T <sub>OP-min</sub> ~ T <sub>OP-max</sub>
Power Supply Voltage	± 3%	V <sub>CC</sub>
TX Bias Current	± 10%	
TX Optical Power	± 3dB	P <sub>O-min</sub> ~ P <sub>O-max</sub>
RX Optical Power	± 3dB	P <sub>S</sub> ~ P <sub>in</sub>

**Status Bits (2 Wire Address A2h)**

Address	Bit	Name	Description
110	7	TX Disable State	Digital state of the TX Disable Input Pin.
110	6	Soft TX Disable	Not implement.
110	5	Reserved	
110	4	RX Rate Select State	Not implement.
110	3	Soft RX Rate Select	Not implement.
110	2	TX Fault	Digital state of the TX Fault Output Pin.
110	1	LOS	Digital state of the LOS Output Pin.
110	0	Data_Ready_Bar	

**Alarm and Warning Flag Bits (2 Wire Address A2h)**

Address	Bit	Name	Description
112	7	Temp High Alarm	Set when internal temperature exceeds high alarm level.
112	6	Temp Low Alarm	Set when internal temperature is below low alarm level.
112	5	Vcc High Alarm	Set when internal supply voltage exceeds high alarm level.
112	4	Vcc Low Alarm	Set when internal supply voltage is below low alarm level.
112	3	TX Bias High Alarm	Set when TX Bias current exceeds high alarm level.
112	2	TX Bias Low Alarm	Set when TX Bias current is below low alarm level.
112	1	TX Power High Alarm	Set when TX output power exceeds high alarm level.
112	0	TX Power Low Alarm	Set when TX output power is below low alarm level.
113	7	RX Power High Alarm	Set when Received Power exceeds high alarm level.
113	6	RX Power Low Alarm	Set when Received Power is below low alarm level.
113	5-0	Reserved Alarm	
114	All	Reserved	
115	All	Reserved	
116	7	Temp High Warning	Set when internal temperature exceeds high warning level.
116	6	Temp Low Warning	Set when internal temperature is below low warning level.
116	5	Vcc High Warning	Set when internal supply voltage exceeds high warning level.
116	4	Vcc Low Warning	Set when internal supply voltage is below low warning level.
116	3	TX Bias High Warning	Set when TX Bias current exceeds high warning level.
116	2	TX Bias Low Warning	Set when TX Bias current is below low warning level.
116	1	TX Power High Warning	Set when TX output power exceeds high warning level.
116	0	TX Power Low Warning	Set when TX output power is below low warning level.
117	7	RX Power High Warning	Set when Received Power exceeds high warning level.
117	6	RX Power Low Warning	Set when Received Power is below low warning level.
117	5-0	Reserved Warning	
118	All	Reserved	
119	All	Reserved	

**Package Outline Drawing**

**(1)LC Type (SI & SJ Series)**

DIMENSIONS ARE IN MILLIMETERS (unit:mm)

ALL DIMENSIONS ARE 0.2mm UNLESS OTHERWISE SPECIFIED

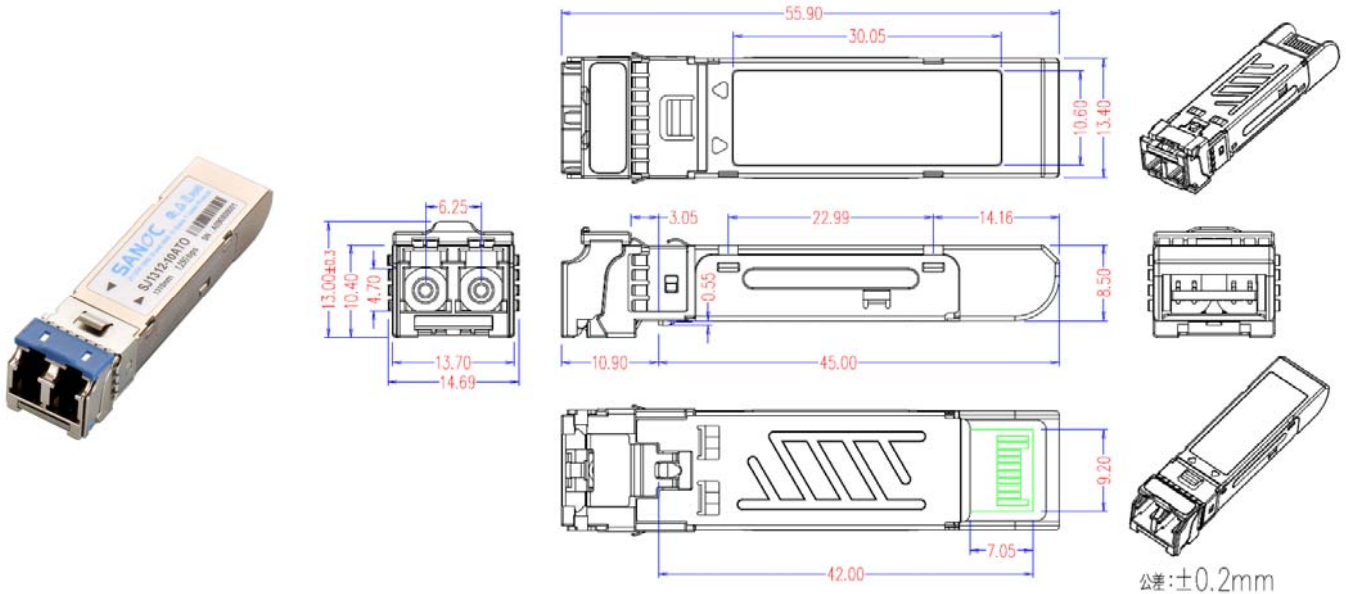

**SFP host board mechanical layout**

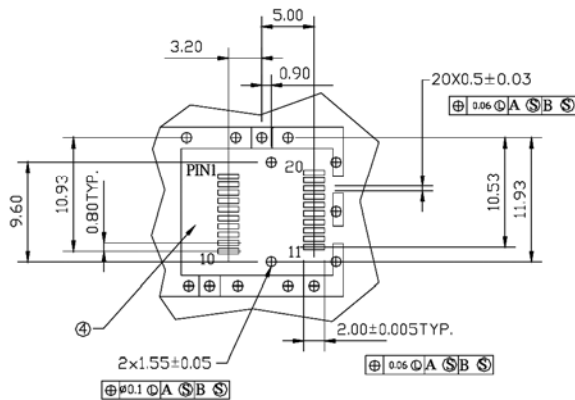
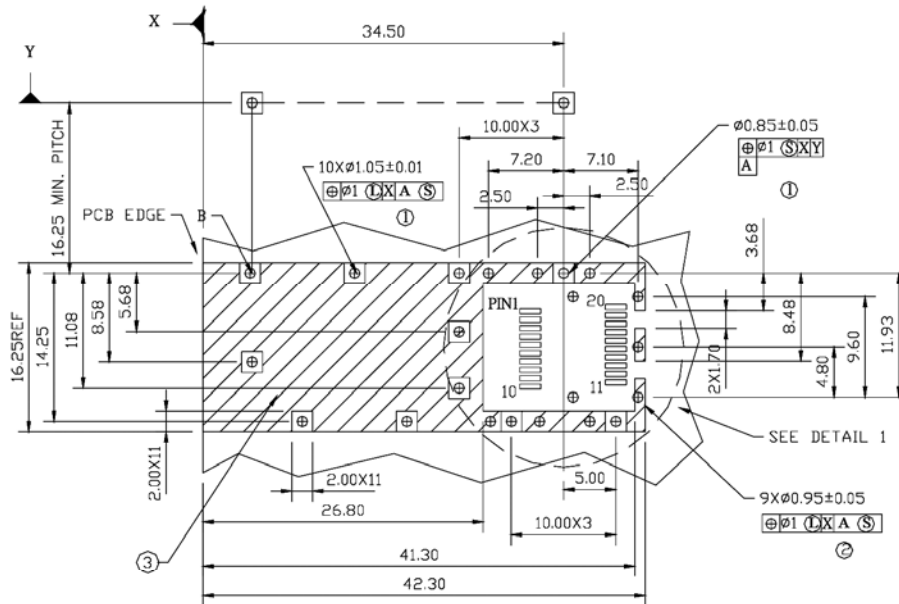

DETAIL 1

**LEGEND**

- 1. PADS AND VIAS ARE CHASSIS GROUND
- 2. THROUGH HOLES, PLATING OPTIONAL
- 3. HATCHED AREA DENOTES COMPONENT AND TRACE KEEPOUT (EXCEPT CHASSIS GROUND)
- 4. AREA DENOTES COMPONENT KEEPOUT (TRACES ALLOWED)

DIMENSIONS ARE IN MILLIMETERS

**Assembly drawing**

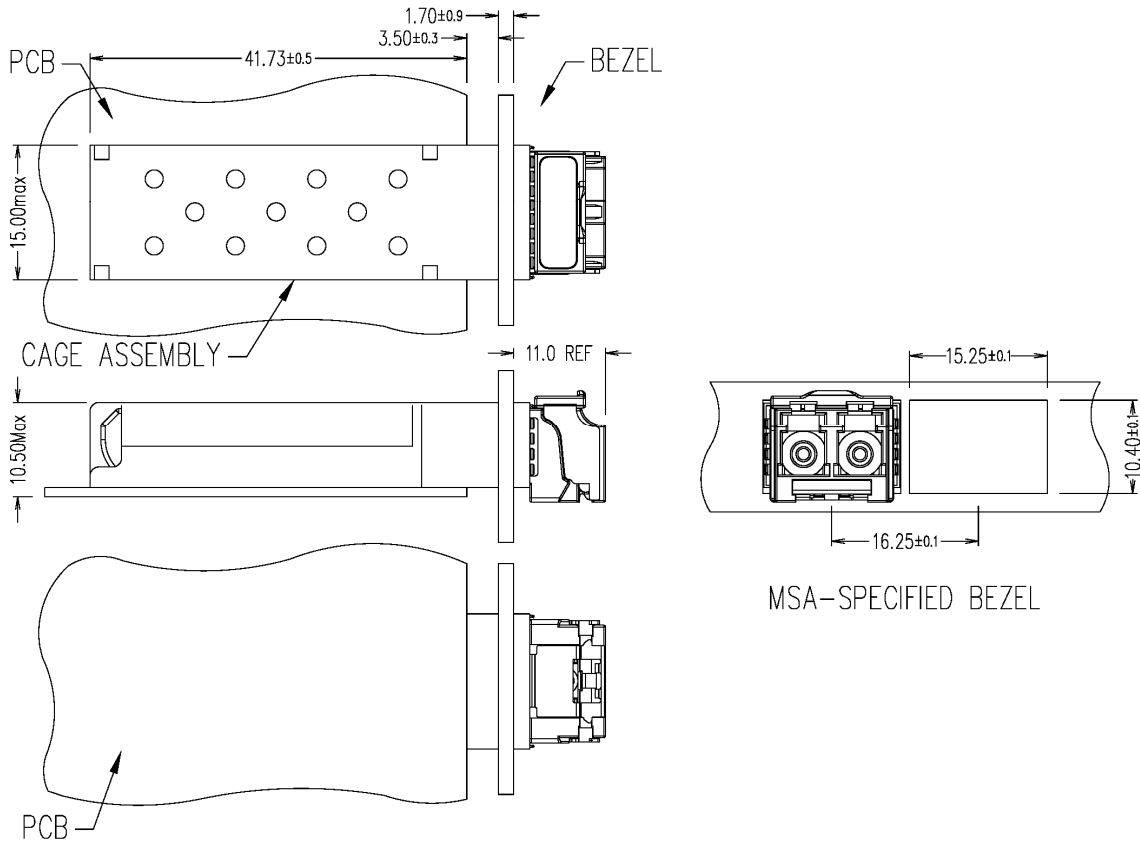

**Eye Safety**

The transceiver is a class 1 laser product. It complies with EN 60825-1 and FDA 21 CFR 1040.10 and 1040.11. In order to meet laser safety requirements the transceiver shall be operated within the Absolute Maximum Ratings.

**Caution**

All adjustments have been done at the factory before the shipment of the devices. No maintenance and user serviceable part is required. Tampering with and modifying the performance of the device will result in voided product warranty.

文件名稱	SI.SJ1562-80ATOS_V3.3		文件編號	1011-1562801220	
版本	發行日期	撰寫者/修改者	變更內容		
V3.0	2015/8/13	潘瑋君	重新發行		
V3.3	2015/10/27	潘瑋君	加入文件履歷		
核 准	廖育聖	制 定 人	潘瑋君	制訂單位	研發部
				發行蓋章處	